



garden power switch box 2/3/4/5 way

Congratulations on buying a Blagdon Powersafe Switch box.

The Powersafe range of switch boxes has been specifically designed to protect your equipment from failure. Each individual double pole switch gives total electrical isolation when switched off. Each switch features the unique at-a-glance power status indication system, which enables quick identification of power on, power on standby and power failure due to a blown fuse. Each switch has an individual fuse to provide overload protection ensuring that even if one or more items of equipment fail, the other essential equipment is still able to function.

IMPORTANT

Please attach proof of purchase to this manual and file in a safe place.

CONTENTS

Getting to know your Powersafe Switch box	2	Maintenance	7
Wiring diagram.....	inside front cover	Replacing a fuse	7
Parts description	inside front cover	Maintenance	7
Spares codes	2	Faults problems procedure	8
Technical specification	2	Consumer advice contact details	8
Installation	3 - 7	Returning a faulty Switch box	8
Mounting the Switch box	4		
Electrical installation	4 - 7		

GETTING TO KNOW YOUR GARDEN POWER SWITCH BOX





Part Description	Spare Code
Cover locating screws (set of four)	1040372
Fixing bracket	1040389
Fixing bracket screws and plugs set	1040396
2/3 switch cover seal	1040402
4/5 switch cover seal	1040419
Cable gland rubber seal and plug	1040426

Part Description	Spare Code
5 AMP fuse	1040433
1.5 AMP fuse	1040440
Cable clamp and screws	1040457
Central PCB locating screw	1040464
Rubber switch cover button	1040471

TECHNICAL SPECIFICATION CHART

SWITCH BOX	2 WAY	3 WAY	4 WAY	5 WAY
Voltage	220/240V	220/240V	220/240V	220/240V
Hertz	50/60	50/60	50/60	50/60
Safety rating	IP56	IP56	IP56	IP56
Maximum cable size External diameter (3 core 1.5 flex)	9mm	9mm	9mm	9mm
Maximum power output 1	1000W	1000W	1000W	1000W
Maximum power outputs 2-5	1x300W	2x300W	3x300W	4x300W



-  **GREEN LIGHT**
Switch box mains supply on
- Individual switch power outlets**
-  **GREEN LIGHT**
Switch on, power supply on
-  **RED LIGHT**
Switch off, power supply on standby
-  **NO LIGHT**
Switch on or off. Fuse has blown, no power.

INSTALLATION

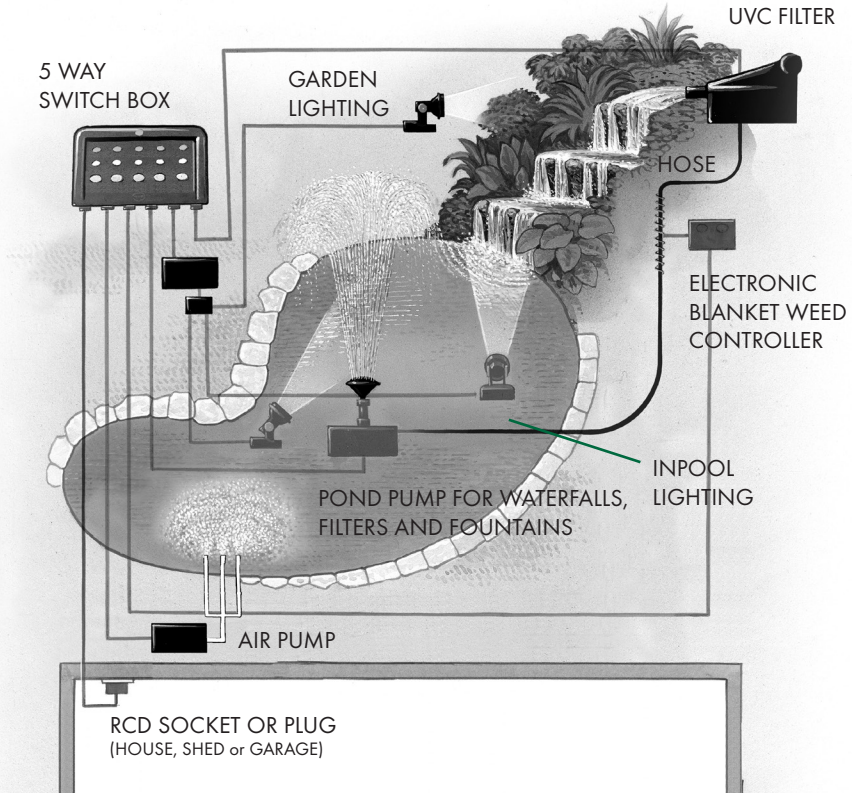

Example shown is 5 way Garden Power Switch box

IMPORTANT: This outlet box is intended to be used with either a weatherproof cable connector or permanently connected to the fixed wiring of the mains system other than by means of a plug and socket. A Residual Current Device (RCD), also known as Residual Current Circuit Breaker (RCCB), having a tripping current not exceeding 30mA must be installed in the supply circuit.

This unit should be connected to a mains supply that is fused with a 13 amp fuse or 15 amp circuit breaker.

IMPORTANT: Do not drill or modify the product in any way! Do not use the product if it is damaged.

INSTALLATION

IMPORTANT: Please note all electrical work on garden lighting and power installations must comply with part P of the building regulations. Failure to comply is a criminal offence. If the installation of this product is not carried out by a competent electrician who is registered under the Part P self-certification scheme then you must notify the local building control department before work begins. For further information and guidance on this matter and other electrical installations in your home that might be covered by the relevant legislation, contact your local authorities building control department.

Switch Box Mounting

The Switch box should be situated in a site that is protected from:

- Flooding
- Extreme heat
- Physical damage
- Tampering by adults children or pets

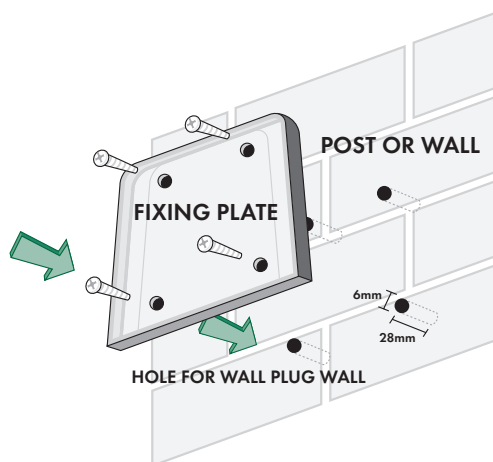

Installation step by step

IMPORTANT: Before removing the cover for wiring or adding additional appliances to the Switch box always ensure that the mains power supply is off and isolated.

Remove the Switch box from the mounting bracket.

Unscrew the four screws at the back of the box to remove the Switch box cover.
Place in a safe location.

INSTALLATION

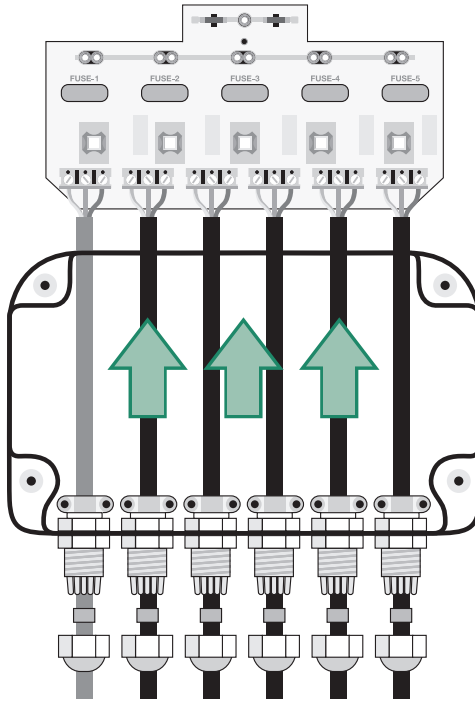

Circuit Board Removal

Remove the circuit board by unscrewing the locating screw and wire each appliance before replacing and locating into the box.

1. Prepare the cable (see cable preparation diagram - inside front cover).
A maximum external cable diameter of 9mm is permitted.

IMPORTANT: Please note that the mains input must be connected to the green power input cable block only.

Switch one has a maximum loading of 1000w 1.0KW.

Switch two and subsequent switches are rated to a maximum wattage of 300w 0.3 KW.

These ratings must not be exceeded by the maximum wattage stated on the appliance to be fitted to each switch.

2. Remove the cable gland cover and thread it over the cable of the appliance to be fitted.
(see gland detail diagram on colour Switch box wiring diagram - inside front cover).

Note: The cable glands have a plug that should be retained if the gland is not being used for a application. This should be inserted to maintain a weatherproof seal.

INSTALLATION

3. Remove the rubber seal from the cable gland and thread it over the cable of the appliance to be fitted. At this stage leave the gland cover and rubber seal loose on the cable.
4. Remove the central circuit board locating screw that locates the circuit board and store in a safe place.
5. Unclip and remove the circuit board, placing it on a clean dry surface.
6. Undo (slacken) the two screws that locate the cable clamp and insert the cable through the cable clamp. At this stage leave the cable clamp loose.
7. Undo (slacken) the three screws on the cable block to be connected.

8. **IMPORTANT:** Please also see diagram cable preparation for correct identification of earth, neutral and live cables.

- Insert the Yellow/green (E) Earth cable and secure with the cable block screw.
- Insert the Blue (N) Neutral cable and secure with the cable block screw.
- Insert the Brown (L) Live cable and secure with the cable block screw.
- Double insulated appliances do not have a earth cable.

Now repeat this process for all the appliances to be connected at this time.

9. When the mains input and ALL the appliances to be connected have been connected and are in place, replace the circuit board into the Switch box (gently pulling the cables through the gland) and secure with the central circuit board locating screw.
10. The cable clamps can now be secured with the two screws to ensure there is no wiring movement.
11. Insert the rubber seal that was previously threaded onto the cable into the seal grip on the cable gland. (see cable gland sealing diagram)
12. Screw and hand tighten the cable gland cover that was previously threaded onto the cable to the cable gland.
Now repeat this process for all the appliances to be fitted at this time.
13. Ensuring that the recessed Switch box cover seal is located, place the cover onto the box and secure with the four screws at the back of the box.
14. Identify the appliances installed with the labels provided in the recess above the relevant switch to enable clear identification when the box is in use.
15. The unit can now be placed on the fixing bracket provided by sliding the box vertically down onto the bracket.

See power status indicator lights diagram page 2 for status of the Switch box when the power is supplied to the unit.

INSTALLATION

Switch Box Mounting

See power status indicator lights diagram page 2 for status of the Switch box fuses. If one of the fuses fails the power indicator will not light on the switch that has failed. Please note that if the power supply to the switch box has been switched off or interrupted due to the RCD circuit breaker or fuse from the mains supply isolating the box none of the indicator lights will illuminate. Before replacing the fuse please check the manufacturer's manual of the appliance that has caused the fuse to blow. The product may be faulty and in need of replacement or servicing by the manufacturer.

(1 x 5 AMP and 1 x 1.5 AMP spare fuses are located for your convenience on the circuit board.)

IMPORTANT: Always switch off the mains power and isolate the Switch box before removing the cover.

3. Remove the Switch box from its mounting bracket by lifting in a vertical action.
2. Remove the four cover locating screws from the back of the box.
3. Having identified which switch fuse has blown (5 amp for switch 1 or 1.5 amp for subsequent switches), remove the blue fuse cover and gently remove the fuse with an electrical screwdriver.
4. Gently push the new fuse into place and replace the fuse cover (see page 2 for replacement fuse codes)
5. Replace the box cover ensuring that the cover seal is in place with the four screws at the back of the box.
6. Slide the Switch box vertically down onto the locating bracket.

Maintenance

It is recommended that once a season the cover seal and rubber buttons are checked for wear and damage to ensure that a safe weatherproof seal is maintained.

If signs of wear are shown, remove and replace the parts (spares codes and descriptions page 2). These should be readily available from your retailer.

IMPORTANT

FAULTS - PROBLEMS PROCEDURE

Before returning your Blagdon pump to your dealer or contacting our Consumer Advice Department, please carry out the following steps. These will solve most problems quickly and easily:

1. Ensure electrical procedure has been followed fully. Check fuses and any cable connectors or switch boxes.
2. Follow the maintenance steps from page 8, follow the troubleshooting options from page 12
3. Return pump to point of purchase for inspection and advice (proof of purchase may be required)

CONSUMER ADVICE CONTACT DETAILS

Interpet (Blagdon) Consumer Advice Department
Vincent Lane, Dorking, Surrey RH4 3YX

E-mail: customercare@interpet.co.uk
www.blagdonwatergardening.co.uk
www.pondaquariumproblemsolver.co.uk/blagdon

GUARANTEE

This product is guaranteed against defects in material and workmanship for 3 years from the date of purchase, under normal usage. The guarantee DOES NOT APPLY in case of improper use, negligence, lack of maintenance or accidental damage to the Switch box. If the Switch box fails due to a manufacturing fault within this period it will be either repaired or replaced free of charge. Liability is limited to replacement of the faulty product only; no other costs will be reimbursed.

This guarantee is not transferable and does not affect your statutory rights. This guarantee does not confer any rights other than those expressly set out above. Excludes rubber buttons and fuses, which may require replacing annually. If any parts need replacing, spares are available from your retailer.